

**По вопросам продаж и поддержки обращайтесь:**

Архангельск (8182)63-90-72	Краснодар (861)203-40-90	Рязань (4912)46-61-64
Астана (7172)727-132	Красноярск (391)204-63-61	Самара (846)206-03-16
Белгород (4722)40-23-64	Курск (4712)77-13-04	Санкт-Петербург (812)309-46-40
Брянск (4832)59-03-52	Липецк (4742)52-20-81	Саратов (845)249-38-78
Владивосток (423)249-28-31	Магнитогорск (3519)55-03-13	Смоленск (4812)29-41-54
Волгоград (844)278-03-48	Москва (495)268-04-70	Сочи (862)225-72-31
Вологда (8172)26-41-59	Мурманск (8152)59-64-93	Ставрополь (8652)20-65-13
Воронеж (473)204-51-73	Набережные Челны (8552)20-53-41	Тверь (4822)63-31-35
Екатеринбург (343)384-55-89	Нижний Новгород (831)429-08-12	Томск (3822)98-41-53
Иваново (4932)77-34-06	Новокузнецк (3843)20-46-81	Тула (4872)74-02-29
Ижевск (3412)26-03-58	Новосибирск (383)227-86-73	Тюмень (3452)66-21-18
Казань (843)206-01-48	Орел (4862)44-53-42	Ульяновск (8422)24-23-59
Калининград (4012)72-03-81	Оренбург (3532)37-68-04	Уфа (347)229-48-12
Калуга (4842)92-23-67	Пенза (8412)22-31-16	Челябинск (351)202-03-61
Кемерово (3842)65-04-62	Пермь (342)205-81-47	Череповец (8202)49-02-64
Киров (8332)68-02-04	Ростов-на-Дону (863)308-18-15	Ярославль (4852)69-52-93

**Единый адрес:** [beh@nt-rt.ru](mailto:beh@nt-rt.ru) **Веб-сайт:** [www.bhr.nt-rt.ru](http://www.bhr.nt-rt.ru)

## Циркуляционные насосы BFP Buhler

# Circular pumps

## BFP

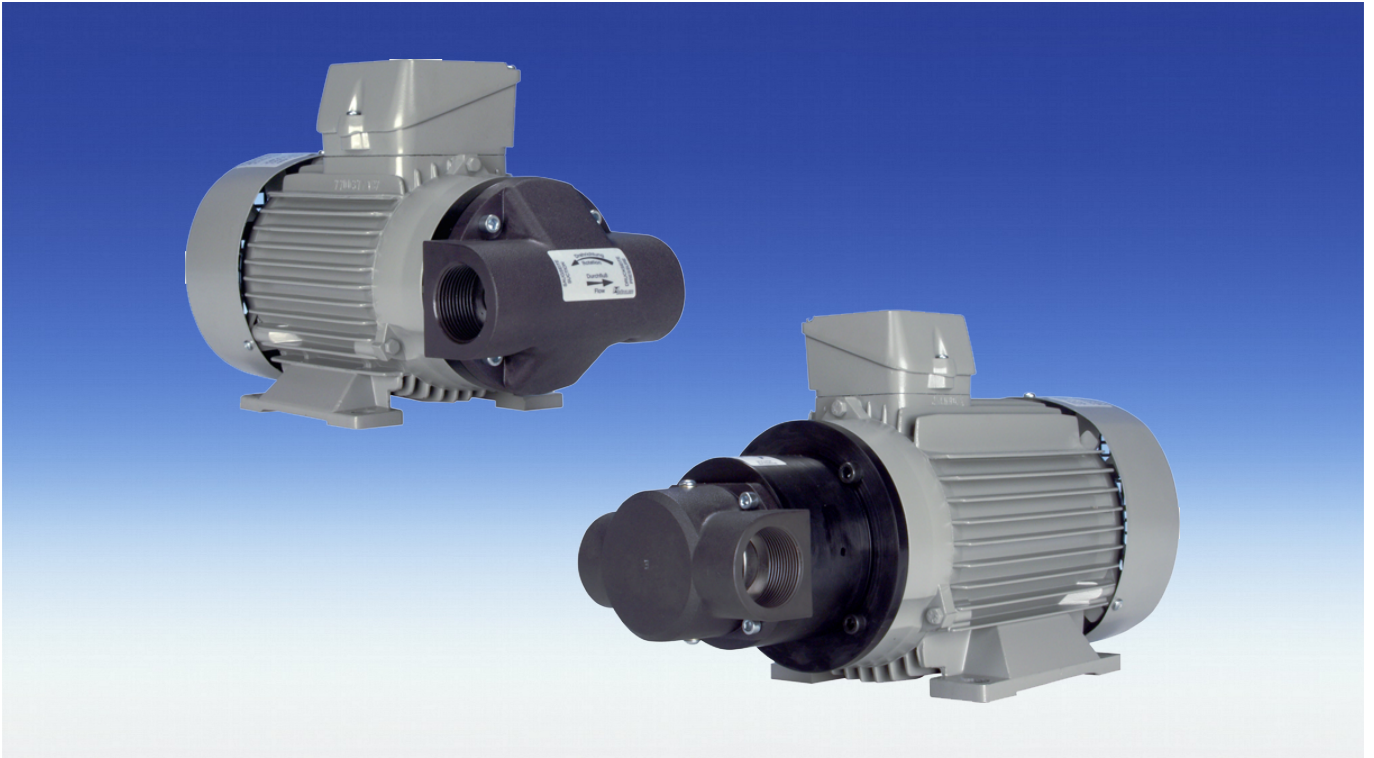

- Low noise emission
- High vol. efficiency
- Good suction performance
- Built-in bell housing
- Gerotor principle
- Not susceptible to contamination

## Introduction and description

### Why gerotor?

Numerous applications in hydraulic and lubrication systems just require the circulation of the fluid. In such cases low noise emissions and low pressure ripples are more important than highly efficient transmission of energy.

The gerotor is the ideal principle for such applications. The displacement mechanism consists of the inner and the outer rotor. The number of teeth of the inner rotor is always one less than the outer rotor. The rotation of the gerotor generates chambers of changing volumes between the inner and outer rotor. The variation follows a sinus curve, resulting in a very steady surge. Due to the inevitable displacement, the flow rate generated is proportional to the rotation speed.

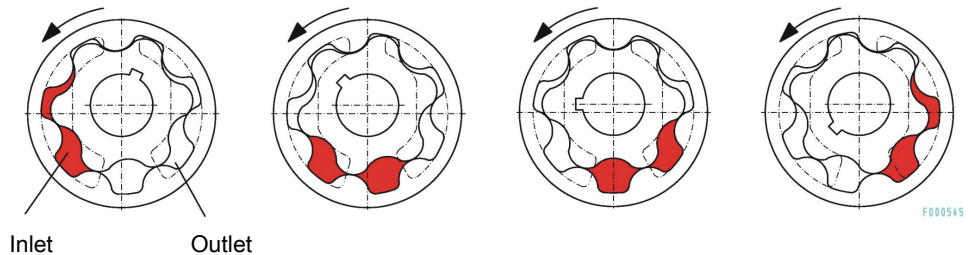

When we designed the BFP series we specifically selected the number of teeth and the width of the gerotors so the pumps have the smallest possible physical dimensions, low weight and minimal loss in efficiency. The low relative speed between the internal and external gear make the pumps extremely durable and smooth.

The internal design of the pumps further reduces the flow paths and ensures good suction performance.

### Why complete pump units?

Every additional component increases the overall installed size of the systems, inevitably increasing the space requirement and typically also the costs. One requirement in developing the BFP series was therefore to keep them as short and compact as possible. On the BFP 8 to 40 models the gerotor is driven directly by the motor shaft. On the larger BFP 60 and 90 pumps the motor shaft is built into a special coupling. The coupling runs in oil and is therefore optimally lubricated and cooled.

## Planning information

### Installation site requirements

Ensure adequate ventilation.

The pumps are mounted in the installation site using four screws

### Electrical connection

The electrical connection must be made by an appropriately trained electrician! Observe the voltage and mains frequency! Fusing must comply with applicable standards! Please note the direction of rotation of the motor when connecting.

### Hydraulic connection

Full utilisation of the high capacity of the pumps requires care when configuring the intake line. This is a very important factor with use in lubricating systems. These are typically filled with higher viscosity oils and must operate reliably in a large temperature range. Although the tremendous increase in viscosity in low temperatures are frequently overlooked. For applications where the parameters are within critical ranges, we recommend calculating the precise expected pressure loss in the suction pipe or using an adequate size (never smaller than the existing pump suction port!).

The suction and pressure pipe must be installed free from tension and vibration. When using hoses, pay particular attention to the appropriate reinforcement on the suction side so the hose cannot collapse due to the negative pressure.

If the pump unit is not already intended for an off-line filter, the oil should have an average purity class of 15/11 per ISO 4406 or better. This is essential in significantly extending the service life of all components.

Do not continuously exceed the recommended suction pressure of the pumps. Some situations may require priming the suction pipe prior to first start-up.

Avoid possible leaks in the circuit to prevent environmental damages. If necessary, use e.g. an oil pan.

## Technical data

Technical data	
<b>Pump housing:</b>	anodised and impregnated cast aluminium
<b>Gerotor:</b>	sintered steel
<b>Operating fluids:</b>	mineral oils per DIN 51524
<b>Operating oil temperature:</b>	max. 80 °C (higher temperatures on request)
<b>Seal:</b>	Perbunan (NBR) Viton (FPM) available on request
<b>Ambient temperature:</b>	-15 °C to +40 °C

Electric motors	
<b>Voltage / frequency:</b>	230 / 400 V - 50 Hz ± 5 % 276 / 480 V - 60 Hz ± 5 %
<b>Thermal stability:</b>	Class of insulation F, utilisation per class B
<b>Design:</b>	three-phase asynchronous squirrel-cage induction motor totally enclosed, fan cooled
<b>Protection class:</b>	IP55
<b>on request:</b>	other voltages higher motor powers for higher viscosities UL- or CSA-approved motors higher protection type
The motors comply with standards IEC 60034, IEC 60072, IEC 60085	

**Please also observe the operating manual for the motor! All pumps are supplied with cable gland inside the motor terminal box. The total length and height of the pump may vary by motor make.**

### Pump selection information:

When selecting the pump model, choose the motor output according to the oil viscosity to be used. Motor output information refers to the maximum oil viscosity at maximum operating pressure.

The BFP 5 to BFP 40 are also available as a special version with a 6 bar internal bypass valve for protection. This does not change the dimensions.

### Installation information:

The pump head of all pumps can be mounted turned in 90° increments to align with the line routing. Please note the offset from the centre of the motor.

The connection threads are manufactured to ISO 228. The screw-in surfaces are finished and suitable for the use of soft seals. We recommend using screwed plugs per ISO 1179-2.

### Please note:

Especially note the dimension of the suction pipe. The cross-sections should not be smaller than specified. In most cases, loud noise indicates the cross-section was reduced too much. Please refer to the notices in the operating instructions.

**BFP 5 / BFP 8 / BFP 15**

	BFP 5-6-0.55kW	BFP 8-4-0.75kW	BFP15-4-0.75kW	BFP15-4-1.1kW	BFP15-4-1.5kW
Item number	3705055	3708075IE2	3715075IE2	3715110IE2	3715150IE2
Motor power	0.55 kW	0.75 kW	0.75 kW	1.1 kW	1.5 kW
Max. oil viscosity	1500 cSt	1500 cSt	300 cSt	1500 cSt	2000 cSt
At max. working pressure	10 bar	10 bar	10 bar	10 bar	10 bar
Number of poles	6	4	4	4	4
Max. current consumption (400V / 50Hz)*	approx. 1.8 A	approx. 2.1 A	approx. 2.1 A	approx. 2.7 A	approx. 3.5 A
Nominal delivery volume*	5.8 cm <sup>3</sup> /U	5.8 cm <sup>3</sup> /U	11.7 cm <sup>3</sup> /U	11.7 cm <sup>3</sup> /U	11.7 cm <sup>3</sup> /U
	5.5 l/min	8 l/min	16 l/min	16 l/min	16 l/min
Suction side connection	G1/2-DN16	G3/4/DN20	G1 1/4-DN32	G1 1/4-DN32	G1 1/4-DN32
Pressure side connection	G3/8-DN12	G1/2-DN16	G1-DN25	G1-DN25	G1-DN25
Suction pressure for all models temporarily up to	-0.4 bar	-0.4 bar	-0.4 bar	-0.4 bar	-0.4 bar
	-0.6 bar				
Acoustic power per ISO 3744*	52 dB(A)	56 dB(A)	59 dB(A)	59 dB(A)	59 dB(A)
Weight	10.8 kg	10.8 kg	10.9 kg	13.2 kg	16.2 kg
Dimensions					
A	96.5	96.5	96.5	96.5	96.5
B	308	308	308	346	368
C	80	80	80	118	140
D	82	82	70	70	70
E	71	71	60	60	60

\* For 60 Hz versions please multiply the delivery volume by a factor of 1.2. The acoustic emission increases by approx. 3 dB.

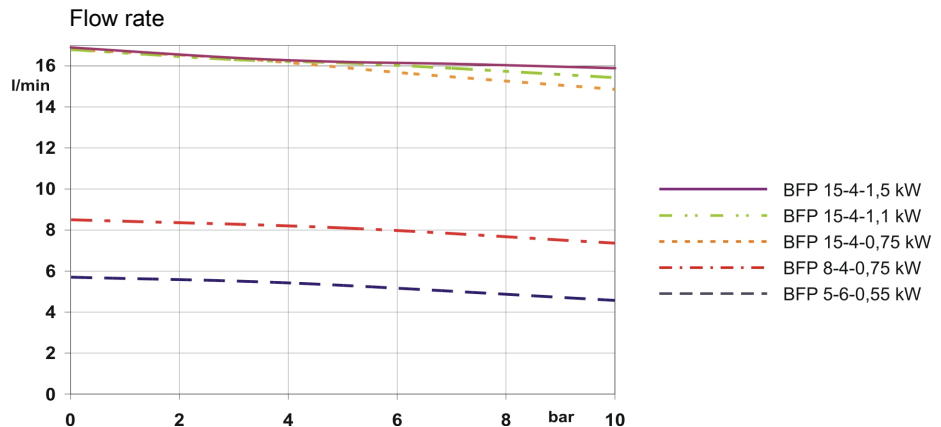
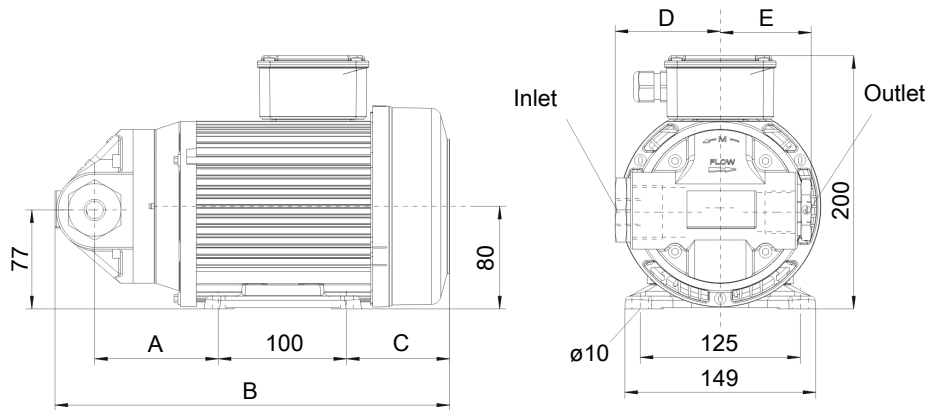

## BFP 30 / BFP 40

	BFP 30-4-0.75kW	BFP 30-4-1.1kW	BFP30-4-1.5kW	BFP40-4-1.1kW	BFP40-4-1.5kW
Item number	3730075IE2	3730110IE2	3730150IE2	3740110IE2	3740150IE2
Motor power	0.75 kW	1.1 kW	1.5 kW	1.1 kW	1.5 kW
Max. oil viscosity	100 cSt	300 cSt	1000 cSt	100 cSt	700 cSt
At max. working pressure	6 bar	8 bar	10 bar	6 bar	8 bar
Number of poles	4	4	4	4	4
Max. current consumption (400V / 50Hz)*	approx. 2.1 A	approx. 2.7 A	approx. 3.5 A	approx. 2.7 A	approx. 3.5 A
Nominal delivery volume*	20.4 cm <sup>3</sup> /U	20.4 cm <sup>3</sup> /U	20.4 cm <sup>3</sup> /U	30.6 cm <sup>3</sup> /U	30.6 cm <sup>3</sup> /U
	29 l/min	29 l/min	29 l/min	42 l/min	42 l/min
Suction side connection	G1 1/4-DN32	G1 1/4-DN32	G1 1/4-DN32	G1 1/4-DN32	G1 1/4-DN32
Pressure side connection	G1-DN25	G1-DN25	G1-DN25	G1-DN25	G1-DN25
Suction pressure for all models temporarily up to	-0.4 bar	-0.4 bar	-0.4 bar	-0.4 bar	-0.4 bar
	-0.6 bar				
Acoustic power per ISO 3744*	61 dB(A)	61 dB(A)	61 dB(A)	62 dB(A)	62 dB(A)
Weight	11 kg	13.2 kg	16.2 kg	13.7 kg	16.7 kg
Dimensions					
A	95	95	95	104.5	104.5
B	306	344	366	354	376
C	80	118	140	118	140

\* For 60 Hz versions please multiply the delivery volume by a factor of 1.2. The acoustic emission increases by approx. 3 dB.

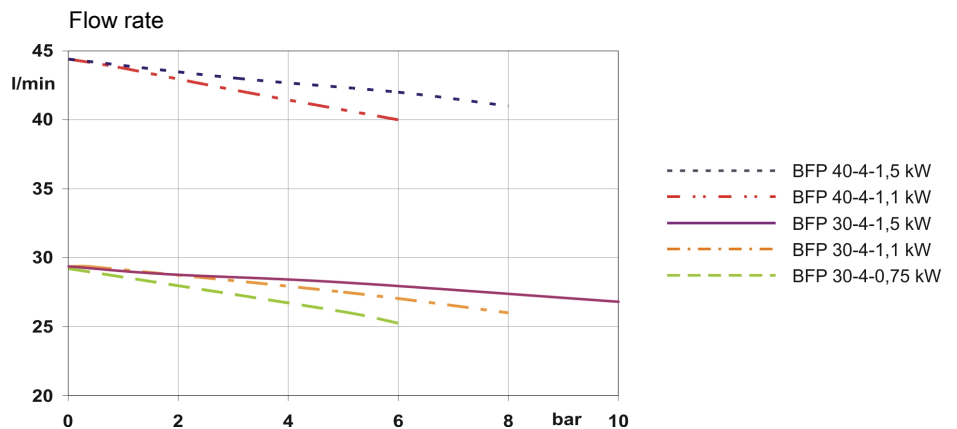
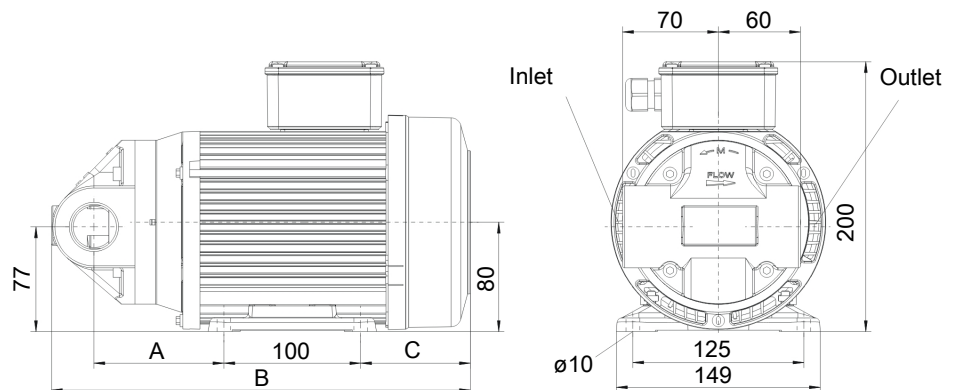

**BFP 60**

	BFP 60-4-1.5 kW	BFP 60-4-2.2kW	BFP 60-4-3kW	BFP 60-4-4kW
Item number	3760150IE2	3760220IE2	3760300IE2	3760400IE2
Motor power	1.5 kW	2.2 kW	3 kW	4 kW
Max. oil viscosity	100 cSt	300 cSt	800 cSt	1500 cSt
At max. working pressure	6 bar	8 bar	10 bar	8 bar
Number of poles	4	4	4	4
Max. current consumption (400 V / 50 Hz)*	approx. 3.6 A	approx. 4.9 A	approx. 6.4 A	approx. 8.3 A
Nominal delivery volume*	40.8 cm <sup>3</sup> /U	40.8 cm <sup>3</sup> /U	40.8 cm <sup>3</sup> /U	40.8 cm <sup>3</sup> /U
	58 l/min	58 l/min	58 l/min	58 l/min
Suction side connection	G1 1/2-DN40	G1 1/2-DN40	G1 1/2-DN40	G1 1/2-DN40
Pressure side connection	G1 1/4-DN32	G1 1/4-DN32	G1 1/4-DN32	G1 1/4-DN32
Suction pressure for all models temporarily up to	-0.4 bar	-0.4 bar	-0.4 bar	-0.4 bar
	-0.6 bar			
Acoustic power per ISO 3744*	64 dB(A)	64 dB(A)	64 dB(A)	64 dB(A)
Weight	17.4 kg	23.2 kg	23.2 kg	32.6 kg
Dimensions				
A	150	172	172	179
B	410	448	466	476
C	104	105	123	126
D	125	140	140	140
E	87	97	97	109
F	90	100	100	112
G	140	160	160	190
H	175	198	198	222
J	226	248	248	276
K	10	12	12	12

\* For 60 Hz versions please multiply the delivery volume by a factor of 1.2. The acoustic emission increases by approx. 3 dB.

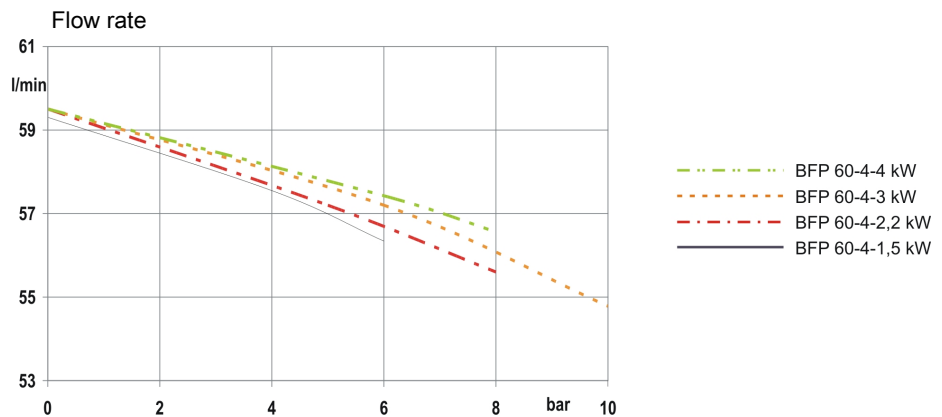
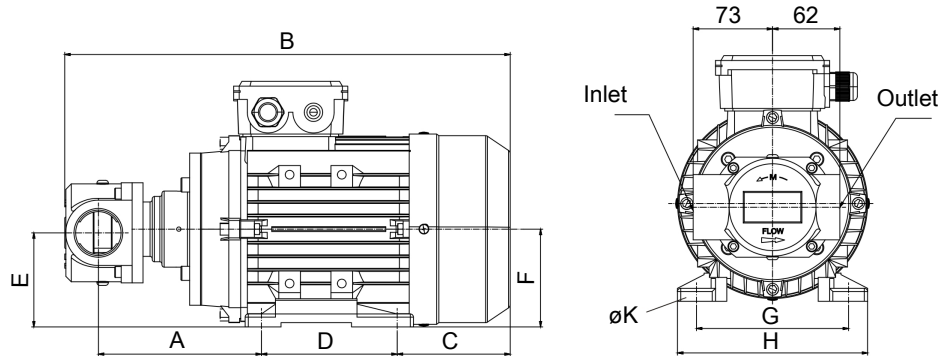

## BFP 90

	BFP 90-4-1.5kW	BFP 90-4-2.2 kW	BFP 90-4-3kW	BFP 90-4-4kW
Item number	3790150IE2	3790220IE2	3790300IE2	3790400IE2
Motor power	1.5 kW	2.2 kW	3 kW	4 kW
Max. oil viscosity	46 cSt	100 cSt	300 cSt	1000 cSt
At max. working pressure	6 bar	8 bar	8 bar	8 bar
Number of poles	4	4	4	4
Max. current consumption (400 V / 50 Hz)*	approx. 3.6 A	approx. 4.9 A	approx. 6.4 A	approx. 8.3 A
Nominal delivery volume*	61.2 cm <sup>3</sup> /U	61.2 cm <sup>3</sup> /U	61.2 cm <sup>3</sup> /U	61.2 cm <sup>3</sup> /U
	88 l/min	88 l/min	88 l/min	88 l/min
Suction side connection	G1 1/2-DN40	G1 1/2-DN40	G1 1/2-DN40	G1 1/2-DN40
Pressure side connection	G1 1/4-DN32	G1 1/4-DN32	G1 1/4-DN32	G1 1/4-DN32
Suction pressure for all models temporarily up to	-0.4 bar	-0.4 bar	-0.4 bar	-0.4 bar
	-0.6 bar			
Acoustic power per ISO 3744*	65 dB(A)	65 dB(A)	65 dB(A)	65 dB(A)
Weight	19 kg	24.8 kg	24.8 kg	34.2 kg
Dimensions				
A	162.5	184.5	184.5	191.5
B	445	483	500	511
C	104	105	122	126
D	125	140	140	140
E	87	97	97	109
F	90	100	100	112
G	140	160	160	190
H	175	198	198	222
J	226	248	248	276
K	10	12	12	12

\* For 60 Hz versions please multiply the delivery volume by a factor of 1.2. The acoustic emission increases by approx. 3 dB.

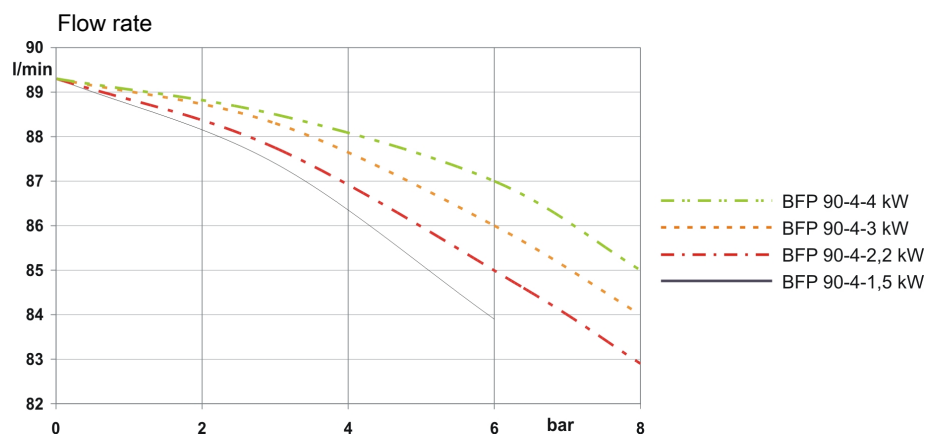
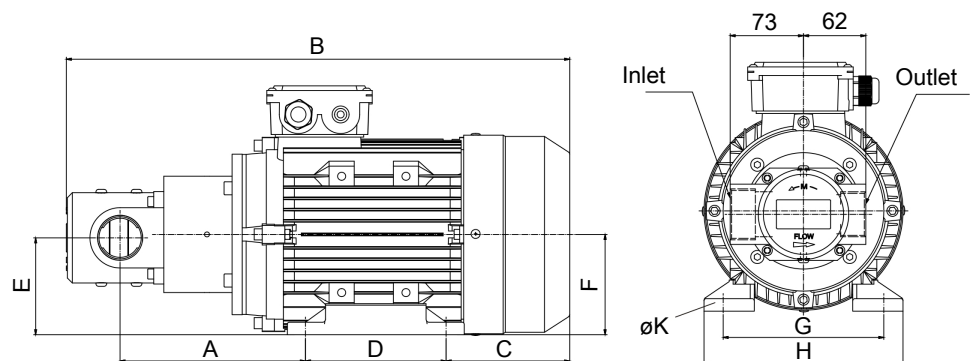



**По вопросам продаж и поддержки обращайтесь:**

Архангельск (8182)63-90-72	Краснодар (861)203-40-90	Рязань (4912)46-61-64
Астана (7172)727-132	Красноярск (391)204-63-61	Самара (846)206-03-16
Белгород (4722)40-23-64	Курск (4712)77-13-04	Санкт-Петербург (812)309-46-40
Брянск (4832)59-03-52	Липецк (4742)52-20-81	Саратов (845)249-38-78
Владивосток (423)249-28-31	Магнитогорск (3519)55-03-13	Смоленск (4812)29-41-54
Волгоград (844)278-03-48	Москва (495)268-04-70	Сочи (862)225-72-31
Вологда (8172)26-41-59	Мурманск (8152)59-64-93	Ставрополь (8652)20-65-13
Воронеж (473)204-51-73	Набережные Челны (8552)20-53-41	Тверь (4822)63-31-35
Екатеринбург (343)384-55-89	Нижний Новгород (831)429-08-12	Томск (3822)98-41-53
Иваново (4932)77-34-06	Новокузнецк (3843)20-46-81	Тула (4872)74-02-29
Ижевск (3412)26-03-58	Новосибирск (383)227-86-73	Тюмень (3452)66-21-18
Казань (843)206-01-48	Орел (4862)44-53-42	Ульяновск (8422)24-23-59
Калининград (4012)72-03-81	Оренбург (3532)37-68-04	Уфа (347)229-48-12
Калуга (4842)92-23-67	Пенза (8412)22-31-16	Челябинск (351)202-03-61
Кемерово (3842)65-04-62	Пермь (342)205-81-47	Череповец (8202)49-02-64
Киров (8332)68-02-04	Ростов-на-Дону (863)308-18-15	Ярославль (4852)69-52-93

**Единый адрес:** [beh@nt-rt.ru](mailto:beh@nt-rt.ru)    **Веб-сайт:** [www.bhr.nt-rt.ru](http://www.bhr.nt-rt.ru)