

По вопросам продаж и поддержки обращайтесь:

Архангельск (8182)63-90-72	Краснодар (861)203-40-90	Рязань (4912)46-61-64
Астана (7172)727-132	Красноярск (391)204-63-61	Самара (846)206-03-16
Белгород (4722)40-23-64	Курск (4712)77-13-04	Санкт-Петербург (812)309-46-40
Брянск (4832)59-03-52	Липецк (4742)52-20-81	Саратов (845)249-38-78
Владивосток (423)249-28-31	Магнитогорск (3519)55-03-13	Смоленск (4812)29-41-54
Волгоград (844)278-03-48	Москва (495)268-04-70	Сочи (862)225-72-31
Вологда (8172)26-41-59	Мурманск (8152)59-64-93	Ставрополь (8652)20-65-13
Воронеж (473)204-51-73	Набережные Челны (8552)20-53-41	Тверь (4822)63-31-35
Екатеринбург (343)384-55-89	Нижний Новгород (831)429-08-12	Томск (3822)98-41-53
Иваново (4932)77-34-06	Новокузнецк (3843)20-46-81	Тула (4872)74-02-29
Ижевск (3412)26-03-58	Новосибирск (383)227-86-73	Тюмень (3452)66-21-18
Казань (843)206-01-48	Орел (4862)44-53-42	Ульяновск (8422)24-23-59
Калининград (4012)72-03-81	Оренбург (3532)37-68-04	Уфа (347)229-48-12
Калуга (4842)92-23-67	Пенза (8412)22-31-16	Челябинск (351)202-03-61
Кемерово (3842)65-04-62	Пермь (342)205-81-47	Череповец (8202)49-02-64
Киров (8332)68-02-04	Ростов-на-Дону (863)308-18-15	Ярославль (4852)69-52-93

Единый адрес: beh@nt-rt.ru **Веб-сайт:** www.bhr.nt-rt.ru

Модифицированные приборы Fluidcontrolterminal FC-T G1/2-75-BMW Buhler

Fluidcontrolterminal FC-T G1/2-75-BMW

- BMW specification -

easyjust

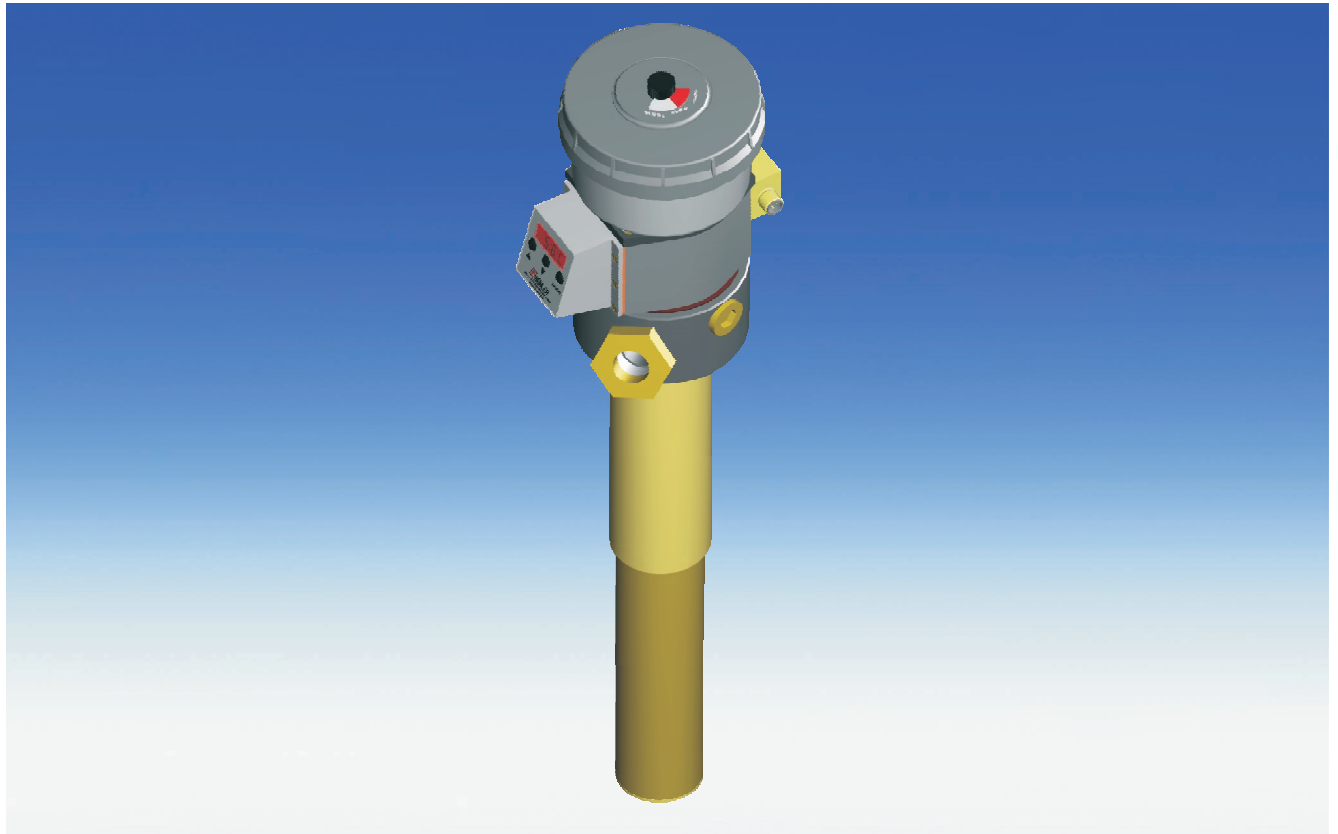

Systematic oil care is of great importance to operators of fluid power and lubrication systems who wish to minimize maintenance costs and optimize the durability of both the oil and system components.

Checking both cleanliness and chemical composition is made easier by having a dedicated sampling port. Topping off the system through a dedicated G1/2 port fitted with a quick release coupling ensures cleanliness and facilitates the use of filter carts.

By incorporating the above features with a level control, temperature control and breather filter with condition indicator, BÜHLER has designed an integrated solution giving cost savings on installation. It should be noted that the filler port is totally isolated from the float tube in order to prevent incorrect level readings while filling/topping off.

The fluidcontrol terminal FC-T G1/2-75-DC 75BMW in the configuration shown complies with BMW requirements. It provides two M12 connector sockets, a temperature display and preset level contacts.

Please note that our product line contains many more options.

- **Level controls**
- **Temperature controls**
- **DIN - flange**
- **Filling port G1/2**
- **3 µm breather filter including fill prevention insert**
- **Clogging indicator**
- **Compact dimensions**
- **Easy installation**

Technical Data

Operating pressure max.	1 bar
Operating temperature max.	80 °C
Density of fluid min.	0.8 kg/dm ³ (0.029 lb/in ³)

Material:

Float SK 610	hard PU
Switch tube	brass
Stilling tube	brass
Flange	galvanised steel
Breather	PA
Retention rate	SM-L = 3 µm

Level contact

Level contact	K101 and K102
Min. distance between contacts	40 mm
Max. voltage	24 V
Max. current	0.5 A
Max. contact load	10 VA

Thermotronic 71

Range of temperature display	from -20 to +120 °C / 4° to 248 °F
Range of alarm indication	0 to +99 °C or 32° to 210 °F
Programmable set points	2
Material housing	PA, IP65
Display	four digit seven segment-LED-display and three light emitting diodes for level status display

Current consumption at power up	about 140 mA for 100 ms
Operating current consumption	approx 30 - 50 mA
Supply voltage	24 VDC ±10 %
Output	PNP
Ambient temperature	0 - 70 °C
Accuracy	1 % of full range
Resolution	1 °C / 2 °F
Programming	via three touch keys
Temperature sensor	PT 100

General description of Thermotronic 71

The Thermotronic 71 is a combined microprocessor controlled digital display and control unit for monitoring and stabilizing the operating temperature in fluid power systems.

The actual temperature is displayed on a high-visibility LED display. The status of the entire unit (output, sensor, broken wire) is indicated by separate LED's. The value can be set to Celsius or Fahrenheit. Programming is by touch keys. The settings are protected against unauthorized operation by key lock.

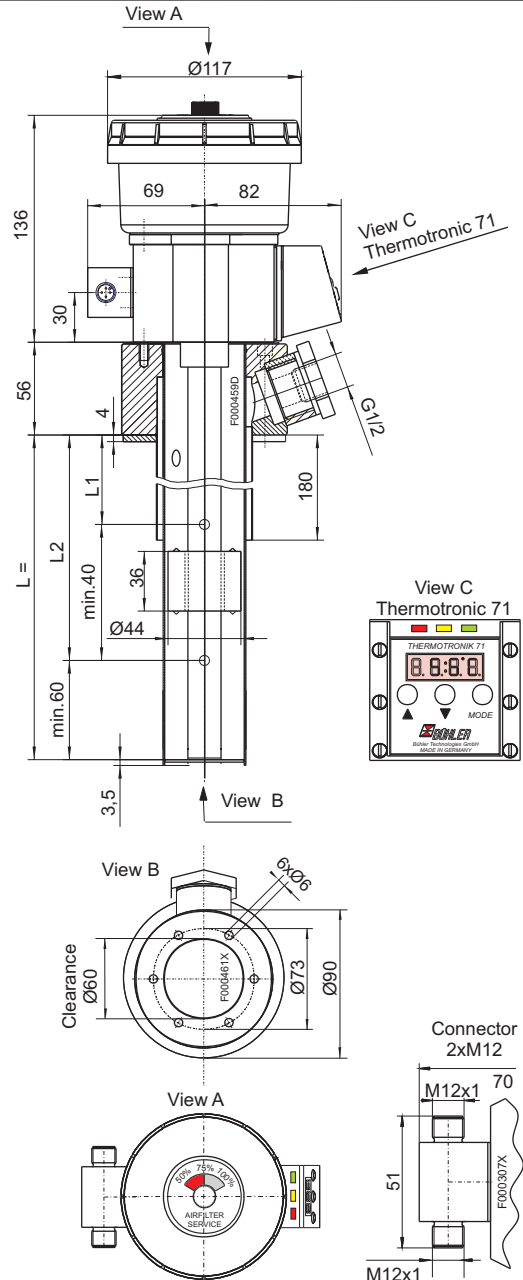

Wiring Diagram

Normal position: float on top = filled reservoir

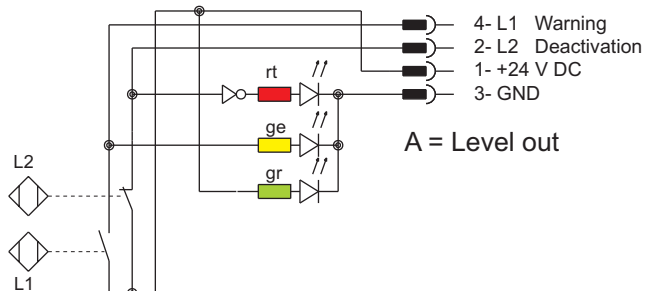
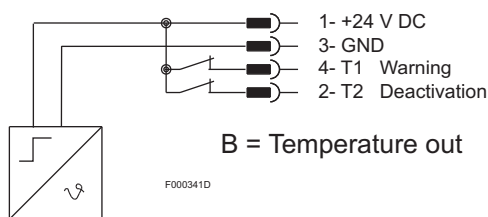

Order Information

FC-Terminal G1/2-75BMW

Part-no	Connector	Display	L =	L1=	L2=	Temperature-contact T1	Temperature-contact T2
1175900401	2xM12	yes	250mm	150 NO *	190 NC *	50°C / NC *	60°C / NC *
1175900402	2xM12	yes	370mm	150 NO *	200 NC *	50°C / NC *	60°C / NC *
1175900403	2xM12	yes	520mm	200 NO *	300 NC *	50°C / NC *	60°C / NC *

*NC=normally closed / NO=normally open

Accessories

Part No. 9144050018

Connecting cable M12x1 with 1 x 5 pole M12 plug cable length: 3,0m

По вопросам продаж и поддержки обращайтесь:

Архангельск (8182)63-90-72	Краснодар (861)203-40-90	Рязань (4912)46-61-64
Астана (7172)727-132	Красноярск (391)204-63-61	Самара (846)206-03-16
Белгород (4722)40-23-64	Курск (4712)77-13-04	Санкт-Петербург (812)309-46-40
Брянск (4832)59-03-52	Липецк (4742)52-20-81	Саратов (845)249-38-78
Владивосток (423)249-28-31	Магнитогорск (3519)55-03-13	Смоленск (4812)29-41-54
Волгоград (844)278-03-48	Москва (495)268-04-70	Сочи (862)225-72-31
Вологда (8172)26-41-59	Мурманск (8152)59-64-93	Ставрополь (8652)20-65-13
Воронеж (473)204-51-73	Набережные Челны (8552)20-53-41	Тверь (4822)63-31-35
Екатеринбург (343)384-55-89	Нижний Новгород (831)429-08-12	Томск (3822)98-41-53
Иваново (4932)77-34-06	Новокузнецк (3843)20-46-81	Тула (4872)74-02-29
Ижевск (3412)26-03-58	Новосибирск (383)227-86-73	Тюмень (3452)66-21-18
Казань (843)206-01-48	Орел (4862)44-53-42	Ульяновск (8422)24-23-59
Калининград (4012)72-03-81	Оренбург (3532)37-68-04	Уфа (347)229-48-12
Калуга (4842)92-23-67	Пенза (8412)22-31-16	Челябинск (351)202-03-61
Кемерово (3842)65-04-62	Пермь (342)205-81-47	Череповец (8202)49-02-64
Киров (8332)68-02-04	Ростов-на-Дону (863)308-18-15	Ярославль (4852)69-52-93

Единый адрес: beh@nt-rt.ru **Веб-сайт:** www.bhr.nt-rt.ru